

DMX Interface User Manual

for GoBoPro+ and GoBoPro FX Projectors

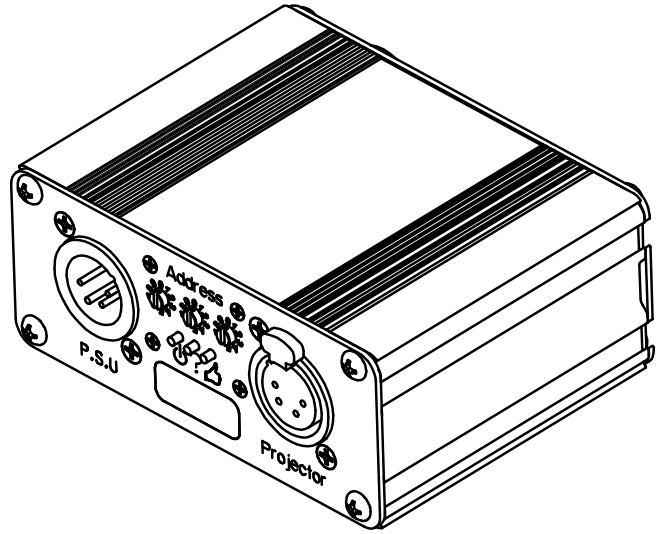

Product Overview



Product Size: 108.5 x 45 x 80mm / 4.27 x 1.77 x 3.15 inches
Product Weight: 250g/ 055 lbs

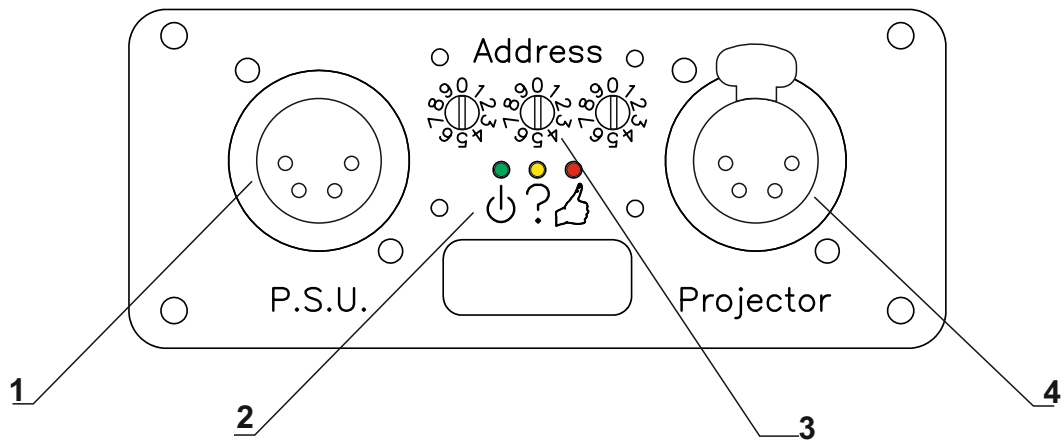

Front Panel Display

1. XLR 4 Pin Input from 28V Power Supply Unit.
2. LED indicators, from left:
 - Green: ON/OFF
 - Yellow: Error
 - Red: Connection Established.
3. Address Switches
4. XLR 4 Pin Output to Projector.

Product Connectivity

Front of DMX box

28V Power in

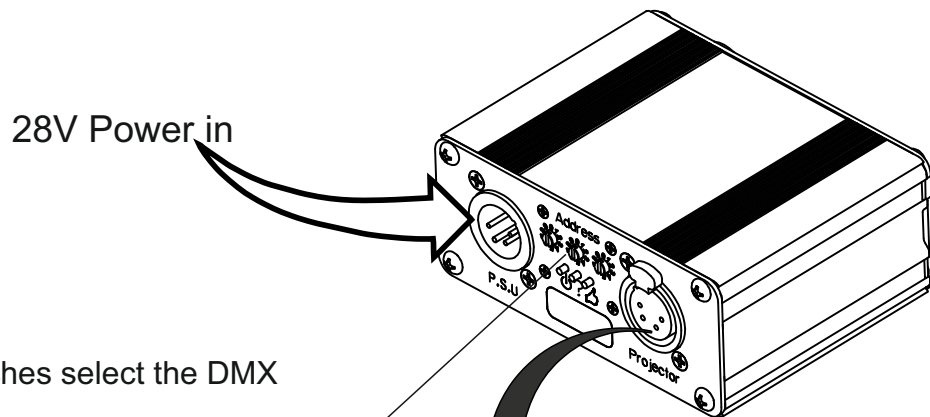

The 3 rotary switches select the DMX base address.
An address of 001 for example the projector would use DMX address 1 and 2, an address of 100 would be address 100 and 101.

4 Pin XLR Female:
Connect to Projector

Pin 1= Gnd
Pin 2 = 28V
Pin 3= Data
Pin 4 & 5= NC

Back of DMX box

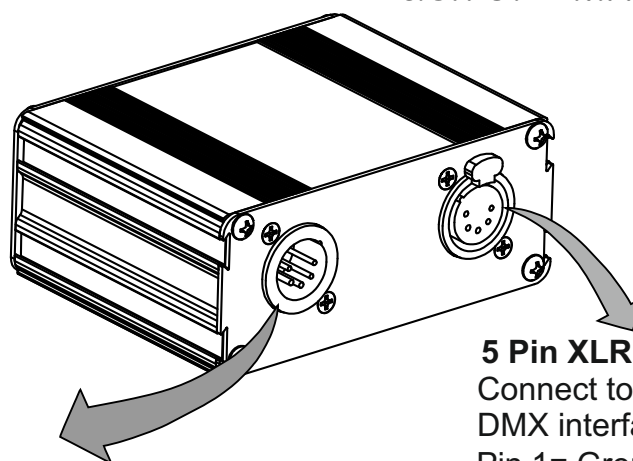

5 Pin XLR Male:
Connect to DMX Mixer Controller
Pin 1= Ground
Pin 2 =Data (Positive)
Pin 3= Data (Negative)
Pin 4 & 5= optional secondary data link

5 Pin XLR Female:
Connect to additional DMX interfaces.
Pin 1= Ground
Pin 2 =Data (Positive)
Pin 3= Data (Negative)
Pin 4 & 5= optional secondary data link

Functionality with GoboPro+

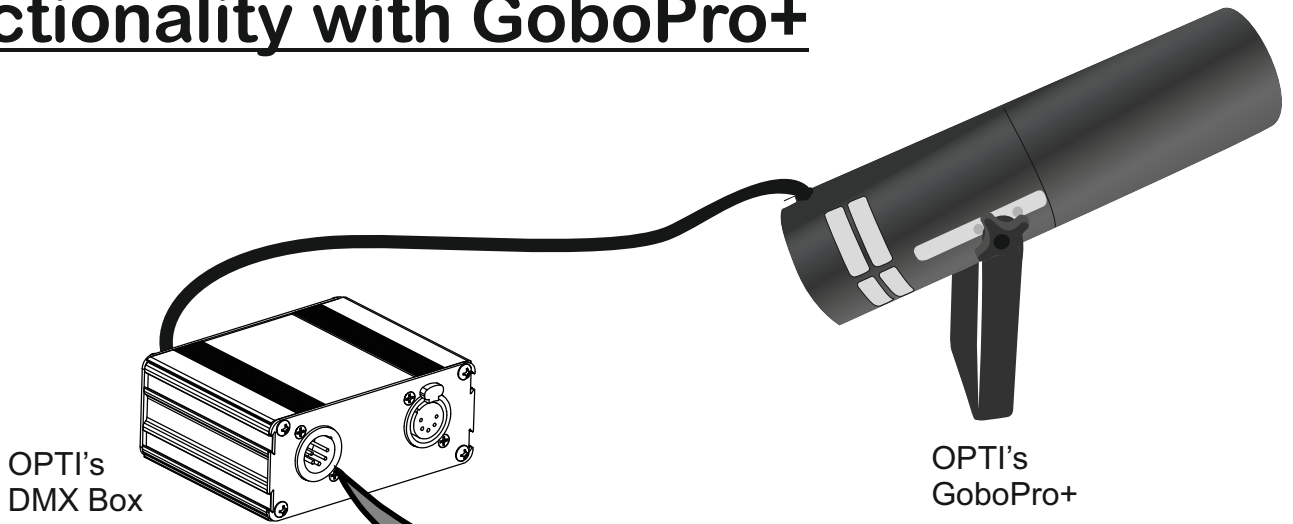

Once, all connections are established, two channels are required for dimming and motor controls respectively. A single channel is used both for direction and speed of rotator. When encoder slides to mid position, image stops spinning. The speed is also gradually reduced as encoder approaches the mid point. Once encoder passes midpoint, image starts spinning in the opposite direction while the speed of rotation gradually increases as the encoder slides to end position. See illustrated figure below.

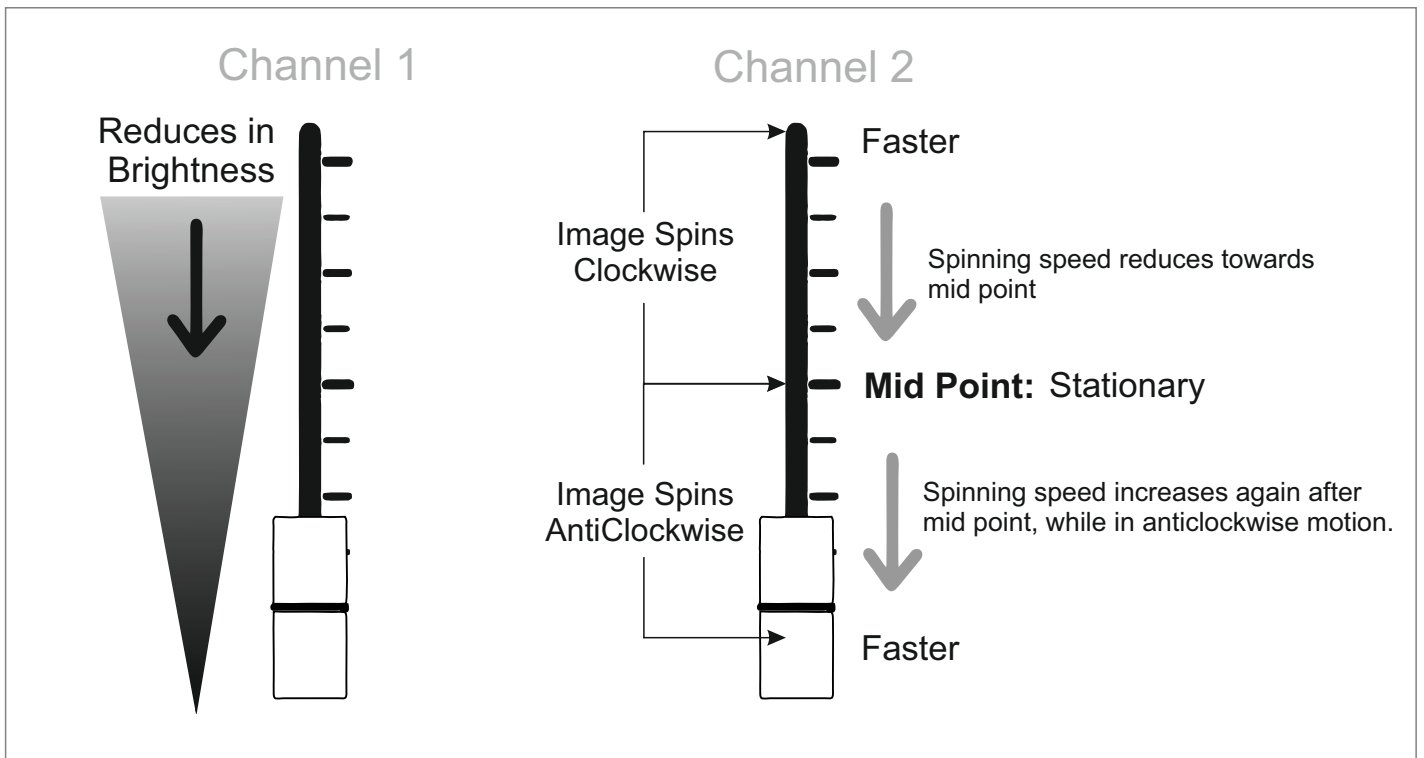
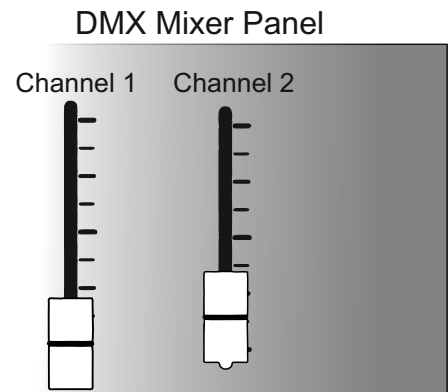

Functionality with FX

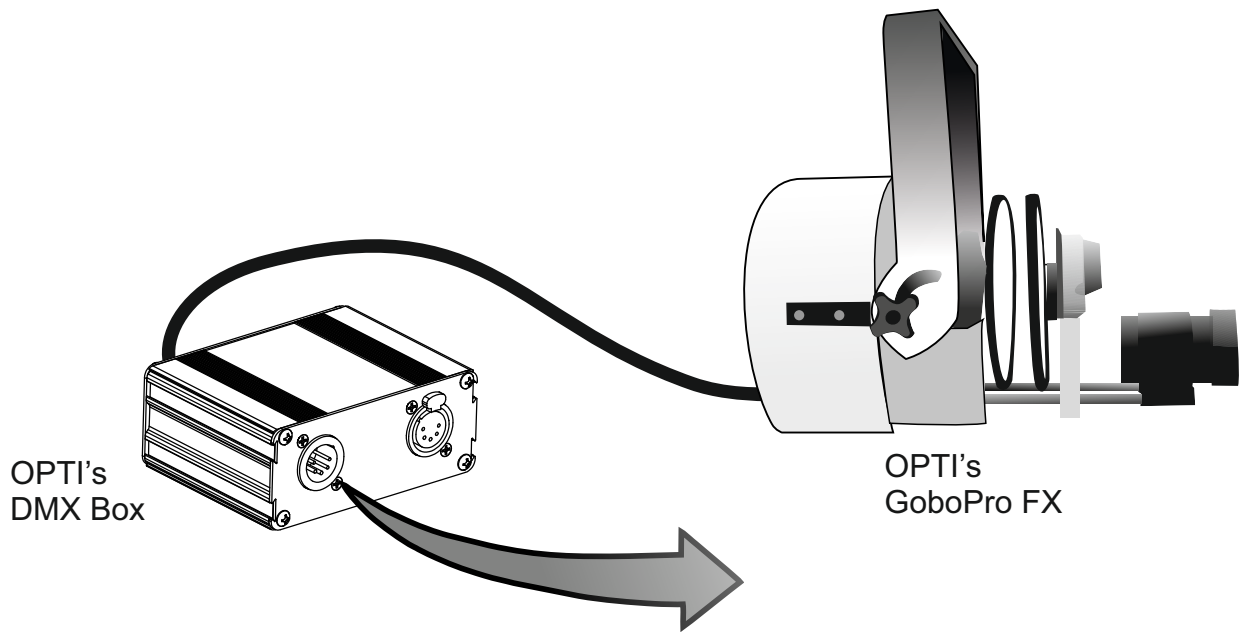

DMX with the GoboPro FX only operates the dimming effect, due to the projector's ability to use Variable Speed Rotators, motor speed control is not controlled by the DMX in this application, but instead via the Rotator cards.

DMX Mixer Panel

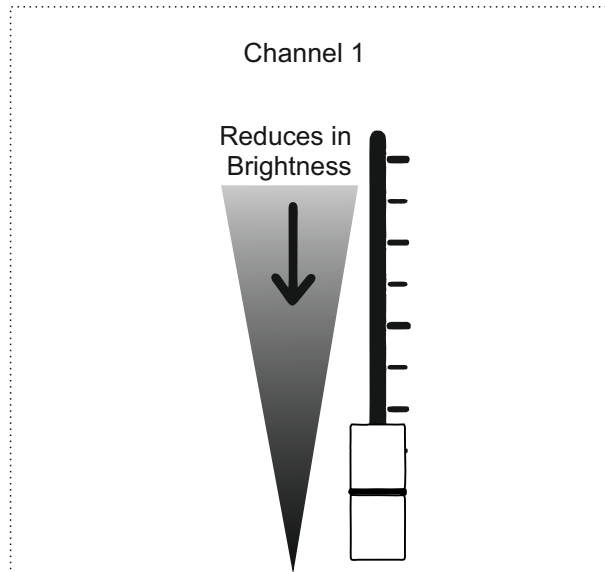

Optikinetics Ltd

38 Cromwell Road
Luton
Bedfordshire
LU3 1DN
England

+44 (0) 1582 411 413
UKAdmin@optikinetics.co.uk

www.optikinetics.co.uk

