

Instructions

Important Safety Instructions

When using your projection equipment basic safety precautions should be followed:

1. Read and understand all instructions before using the equipment.
2. Close supervision is necessary when any appliance is used by, or near, children.
3. Care must be taken, as burns can occur from touching hot parts.
4. Do not operate appliance with a damaged cord, or if the appliance has been dropped, or damaged, until it has been examined by a qualified engineer.
5. Position the cord so that it will not be tripped over, pulled, or come into contact with hot surfaces.
6. If an extension cord is necessary, a cord with a current rating at least equal to that of the appliance should be used. Cords rated for less amperage than the appliance may overheat.
7. Always unplug appliance from electrical outlet before cleaning and servicing and when not in use. Never yank cord to pull plug from outlet. Grasp plug and pull to disconnect.
8. Let appliance cool completely before packing. Loop cord loosely around appliance when storing.
9. To reduce risk of electric shock, do not immerse power supply or other liquids.
10. To reduce the risk of electric shock, do not dismantle this appliance.
11. Do not attempt to service the projector unless you are qualified and working under the direction of the manufacturer
12. The use of an accessory attachment not recommended by the manufacturer may cause a risk of fire, electric shock, or personal injury.
13. A safety chain or cable must be fitted to the projector and secured to an immovable object where applicable. The securing point must be able to withstand the shock weight of the projector should it fall.
14. After any maintenance or cleaning all parts must be absolutely dry before refitting to the projector.
15. During focussing of the projected image beware of moving the projection lens too far, as this may cause the lens to become separated from the projector, and perhaps to dropped and broken which may cause injury.
16. Flammable surfaces should be 0.5m away from the front of the projector



[OPTI]TM Solar FX

Power Supply

A 28V mains supply suitable for 100-240V AC is supplied with an appropriate IEC power cable. The power supply is not suitable for use in wet conditions and should be installed in a dry location or waterproof box. The low voltage power cable can be extended by means of 4-pin XLR extension leads. Power cores should be capable of carrying at least 6A.

Mounting

Solar FX projectors are supplied with one u-shaped bracket that can be mounted to any immovable surface. The mounting bracket hole is 11mm. The angle of the u-shaped bracket can be adjusted using the pivot handles on the side of the projector. If the projector is to be mounted vertically downwards, it is recommended a small disk is installed above the projector to the risk of water pooling in the back of the unit.

Waterproof Hood

Solar FX projectors are supplied with one 200mm long IP-rated 65 hood (suitable for 20mm-120mm lenses). To remove the hood, gently wiggle the hood and pull the hood off. To reattach the hood, gently wiggle and push the hood onto the projector. Please note that there will be a different size hoods available to accommodate 150mm lenses and bigger. There is a 1mm hole at the front of the hood to drain condensation. This hole should be aligned at the bottom of the projector. To secure the hood to the projector.

Lens Fitting & Focusing

If you would like to add or change the lens, loosen the screw on the bottom of the lens housing and remove the lens (if currently inserted). Insert the new lens to a balanced position and tighten the screw on the bottom of the lens housing.

To project a focused image, it is necessary to finely adjust the focusing lens after the unit has been pointed at the desired projection surface. To adjust the focusing lens, loosen the screw on the side of the lens housing and slide the housing along the rails until the image is focussed. Secure the lens housing to the rails by tightening the screw on the side

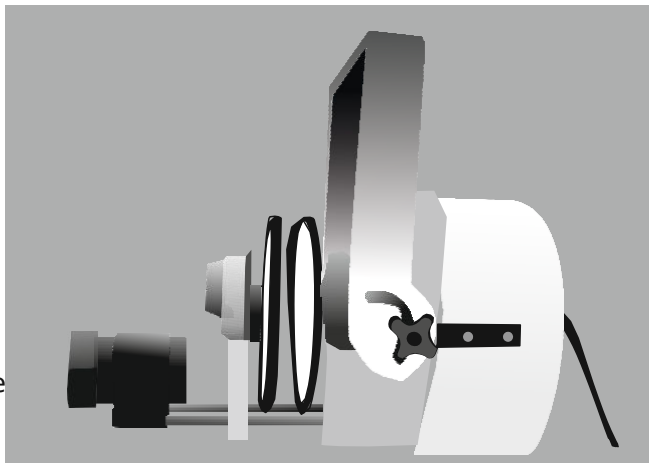
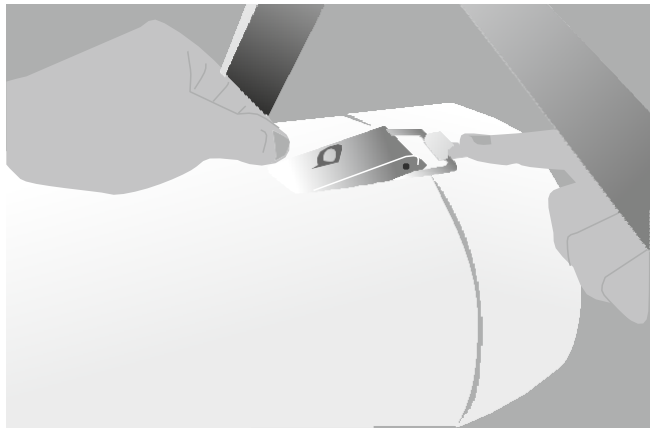
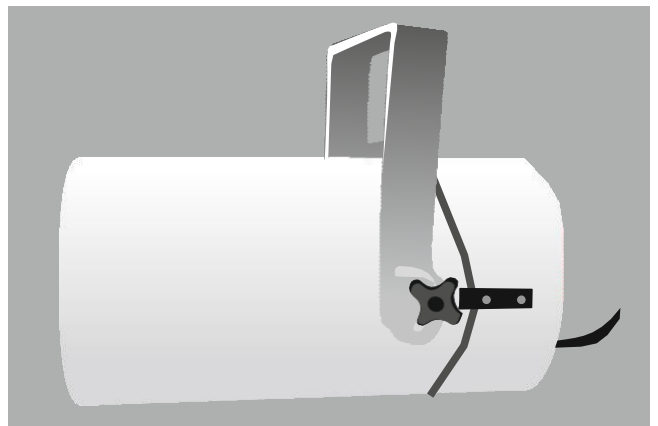
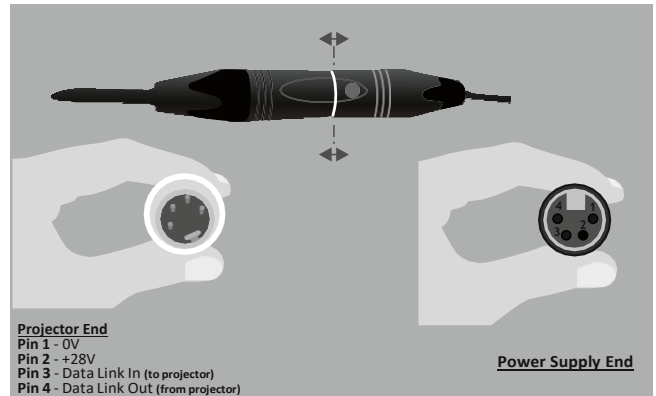

[OPTI]TM Solar FX

Distance Calculation Formula

$$\frac{\text{Lens Focal}}{\text{Object Size}} \times \frac{\text{Projection Distance}}{\text{Image Size}}$$

Please note Solar FX projectors can be used with 52.5mm barrel lenses so there may be other lenses available.

Effects

There are two gates in the projector for holding effects cards (rotators, static gobos etc). The one nearest the light source commonly referred to as the front gate or the first gate, is the one that is normally used for the projected object. (Please note that some effects such as 'Light through Trees' are achieved through deliberately not focussing on the object in the first gate.) Usually the second gate is used to hold distortion wheels or other effects.

The first gate position is integral to the body of the projector. Effect cards are simply slid into the slot of the gate and pick up power from spring connectors inside the gate. Typical first effect cards are wheel rotators such as FGM6340AG or cassette rotators FG6391AG.

The position of the gates is important as it can completely change the image and the effect. Note: If rotating effects, the gates should not be positioned too close together.

Front of Lens Effects

Multi Mirror

A multi mirror can be used with the OPTI Solar FX to create a fantastic multi-image effect.

Lens Focal Length	Projection Distance to Image Size (Ratio)	Lens Degrees
45mm	1:1	50°
60mm	3:2	39°
85mm	2:1	26°
120mm	3:1	18°
150mm	4:1	15°

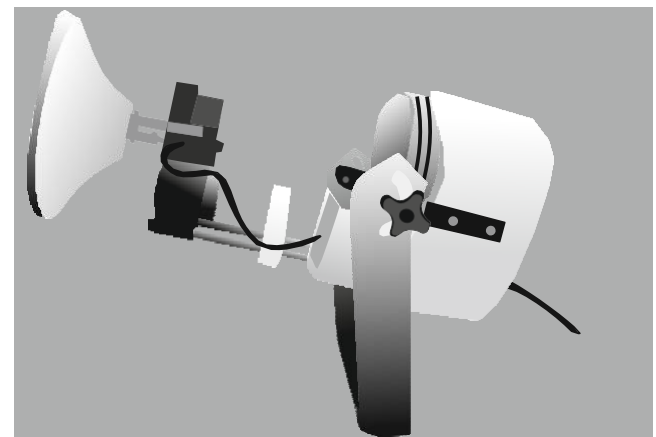
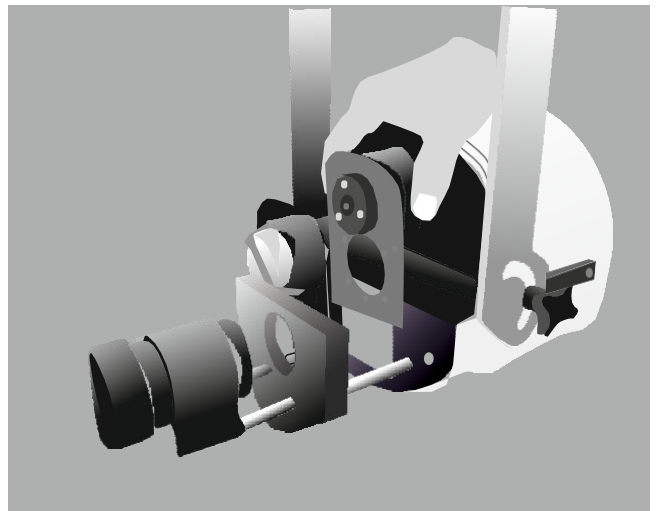
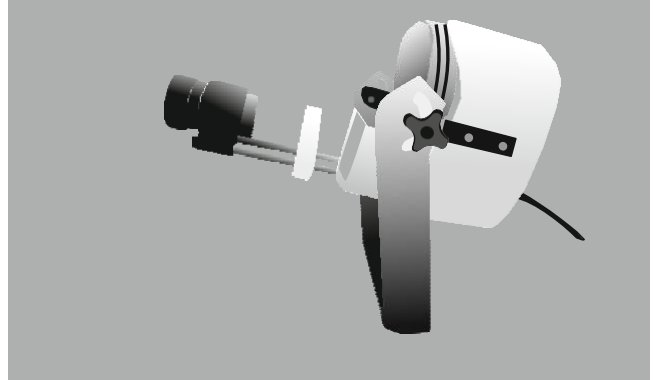

[OPTI]TM Solar FX

Multi-mirror

The multi-mirror can be controlled using the switch and dial buttons on the back of the unit.

The switch controls the direction of the rotation and the dial controls the speed.

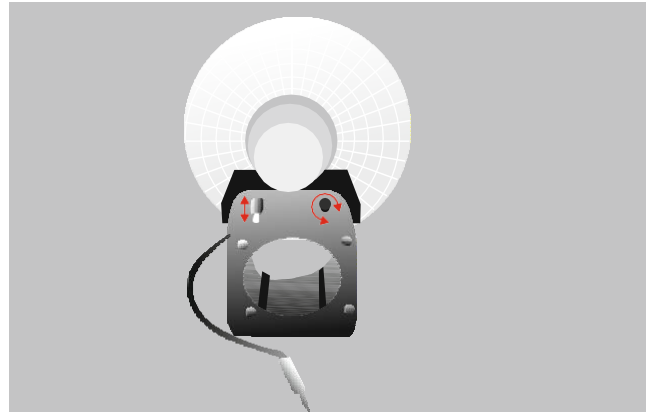

Guarantee

[OPTI] Kinetics Limited guarantees this product for 1 year from the date of purchase from all mechanical, electrical or assembly defect. Within this 1-year period any fault will be repaired or remedied free of charge. To extend the warranty free of charge to 3 years, please register your Solar FX projector by visiting www.optikinetics.co.uk. The guarantee is void if the projector has been opened or if a repair has been attempted by anyone other than an [OPTI] Kinetics authorised repairer.

[OPTI]TM Guarantee



Technical Specification

NAME:	[OPTI] Solar FX LED Projector FG2030
Part Number:	Static and/or rotating image. Integral Rotator for Cassette
Gobo Projection:	Projector takes 52.5mm diameter object lenses. <i>Other lenses available*</i>
Lens Size:	45, 60, 85, 120, 150, Zoom
Lens options:	Manual
Focus:	120W LED
Light Source:	8000 Lumens
Brightness Output:	3800 Lux
Illuminance at 1 meter:	7500 K
Colour temperature (Kovin):	Black or White
Colour of Projector: Effects	Two active gates and one front of lens effect connection
Control:	Manual. DMX and Wifi Adapter Available
Remote control:	Dimming, control of all effect parameters.
Projection Rating:	IP 65 with front cover fitted. Suitable for outdoor use.
Power Supply:	Mains adapter 28V at 4.74A. (Adapters not to IP65).
Dimension of projector:	L38 H37 W37 Od20 CM
Weight:	8Kg

[OPTI] Kinetics

38 Cromwell Road Luton LU3 1DN England
+44 (0)1582 411413 | ukadmin@optikinetics.co.uk | www.optikinetics.co.uk

